

**Description:** Door lock and alarm interface for Audi Q7 and Audi A6.

**Functions:** Lock/Unlock doors, arm and disarm alarm through data bus line.

Downloadable Firmware for Platform #01: ASDL, AUDIDL2, FODL, GMDL6, GMDL7, HODL4, HYDL, KIADL, KIADL2, TOYDL, VWDL, VWDL2

**WARNING:** Before beginning your install go to [www.XPRESSKIT.com](http://www.XPRESSKIT.com) and be sure to print the LATEST corresponding installation manual for the firmware that is flashed to the platform you are using.

SEE WIRE CONNECTION GUIDE FOR DETAILED INFORMATION REGARDING WIRE FUNCTIONALITY

### Section A

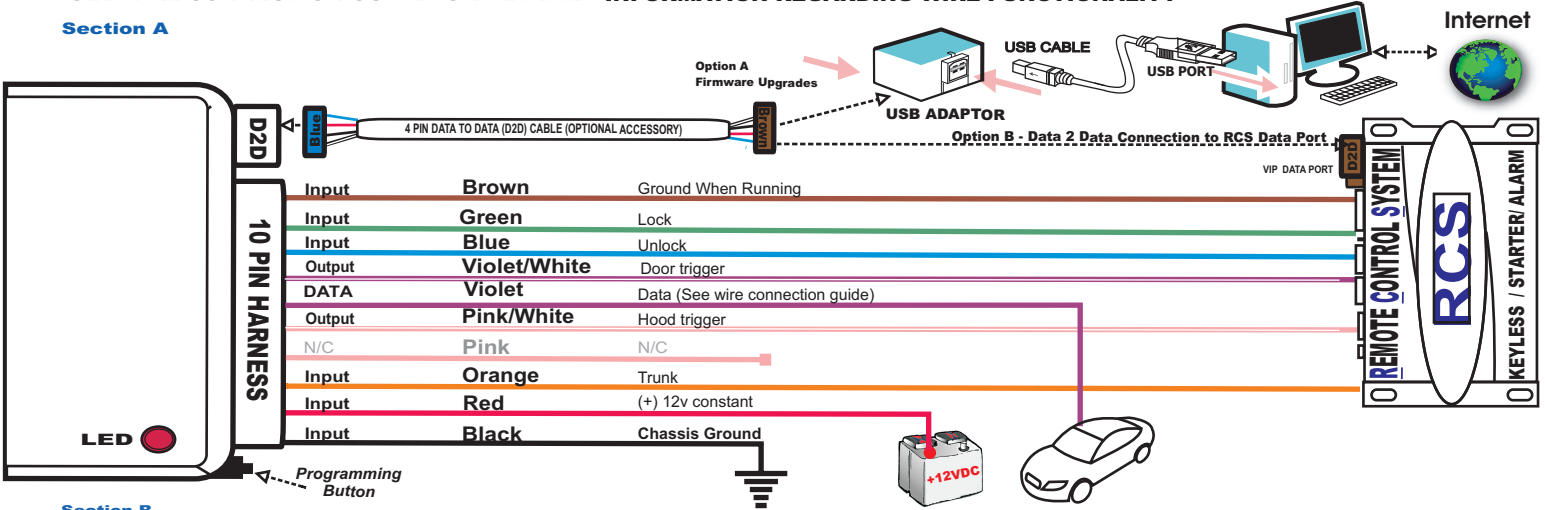

### Section B

## WIRE GUIDE: CONNECTIONS

10 PIN HARNESS → D2D = Optional use of 4 Pin Data to Data (D2D) cable will replace the analogue wire (w2w) connection

PIN	WIRE COLOR	D2D w2w	I/O STATUS	(-) /(+)	Connect Location	SPECIFIC WIRE CONNECTION LOCATION	FUNCTIONS
1	Brown	D2D w2w	Input	(-)	RCS	Connect to the ground when running wire on the remote starter	Arm and disarm of the OEM alarm system.
2	Green	D2D w2w	Input	(-)	RCS	Connect to the lock wire on the remote starter	Lock all doors.
3	Blue	D2D w2w	Input	(-)	RCS	Connect to the unlock wire on the remote starter	Unlock all doors.
4	Violet/ White	D2D w2w	Ouput	(-)	RCS	Connect to the door trigger wire of the remote starter	Detect door status in data and send it through analog signal
5	Violet	w2w	Data		Vehicle	Connect to the Orange/Green wire coming from driver door.	Data command coming from the Module to the vehicle.
6	Pink/ White	D2D w2w	Ouput	(-)	RCS	Connect to hood trigger on the remote starter.	Detect hood status in data and send it through analog signal
7	Pink	N/C	N/C	N/C	N/C	N/C	N/C
8	Orange	D2D w2w	Input		RCS	Connect to the trunk release wire on the remote starter.	Trunk release
9	Red	D2D w2w	Input	(+)	Vehicle	12 volts constant (+)	Power source
10	Black	D2D w2w	Input	(-)	Vehicle	Chassis ground	Ground source

Legend: RCS = Remote Control System N/C = No Connection N/A = Not Applicable W2W= Analogue Wire to Wire D2D= Data 2 Data

**DATA to DATA PORT (D2D):** Blue connector of D2D Cable plugs into the upgradeable vehicle interface module.

OPTION A: - D2D Port used to connect to USB Bootloader adaptor & computer to download & flash vehicle interface firmware.

OPTION B: - D2D Port used to connect to the data port of a remote control system equipped with ClearCode Vehicle Interface Protocol.

Remote control systems designed with ClearCode VIP can securely communicate via the D2D cable to transmit & receive data commands which initiate specific vehicle function such as doorlocks & immobilizer override and /or request information from the vehicle such as status of entry points (doors) or ambient temperature, diesel glow plug etc... ClearCode VIP represents the doorway to vehicle integration...As an enhanced security feature, this upgradeable vehicle interface module automatically detects when the Vehicle Interface Protocol is present and deactivates the analogue override input wire (brown wire) ensuring that this module can only be activated by an authorized user.

### Section C

## PROGRAMMING:

- After connecting the module, the LED comes ON.
- Insert the key and turn it to ignition position, the LED shuts.
- The module is now programmed.

### Section D

## SETUP - OPTIONAL PROGRAMMING:

1- Key "OFF" position, press and hold program button for 2 seconds, LED will flash rapidly for 2 seconds. Release button, LED will show first MODE with slow flash and second will show option with fast flash.

2-To change MODE, push button one time, LED will confirm MODE with slow number of flash.

**N.B.: ONLY MODE 1 AND 8 ARE AVAILABLE**

3-To change OPTION into selected MODE, press LOCK or UNLOCK with remote of alarm or remote starter. LED will show option with fast flash.

4- To save and exit programming, push and hold button until LED flash one time rapidly, showing end of OPTION programming.

### OPTION LIST

\* Default Option

#### MODE 1 - UNLOCK:

\*OPTION 1 = 1 pulse unlock all doors

OPTION 2 = 1st pulse, unlock driver door, 2nd pulse unlock all doors

#### MODE 6 - LOCK AT REMOTE STARTER STOP:

\*OPTION 1 = Activate

OPTION 2 = Deactivate

#### MODE 8 - RESET MODULE

\*OPTION 1 = No Reset

OPTION 2 = Complete reset of OPTION and module (default)

This Interface kit / Data Bus Interface part has been tested on the listed vehicles. Other vehicles will be added to the select vehicle list upon completion of compatibility testing. Visit website for latest vehicle application guide. **DISCLAIMER:** Under no circumstances shall the manufacturer or the distributors of the bypass kit / data bus interface part(s) be held liable for any consequential damages sustained in connection with the part(s) installation. The manufacturer and it's distributors will not, nor will they authorize any representative or any other individual to assume obligation or liability in relation to the interface kit / data bus interface part(s) other than its replacement. N.B.: Under no circumstances shall the manufacturer and distributors of this product be liable for consequential damages sustained in connection with this product and neither assumes nor authorizes any representative or other person to assume for it any obligation or liability other than the replacement of this product only.