

# Platform # 02

# Firmware: HODL

Installation  
Manual (1\2 Pages)

**Description:** Honda/Acura Doorlock Alarm Interface (NO KEY REQUIRED)

**Functions:** Lock/Unlock, Trunk, OEM Security Arm/Disarm

Downloadable Firmware for Platform #02: HODL, NISSDL, SUBDL

**WARNING:** Before beginning your install go to [www.INTELLIKITS.com](http://www.INTELLIKITS.com) and be sure to print the LATEST corresponding installation manual for the firmware that is flashed to the platform you are using.

## Section A

See Wire Connection Guide for detailed information regarding wire functionality

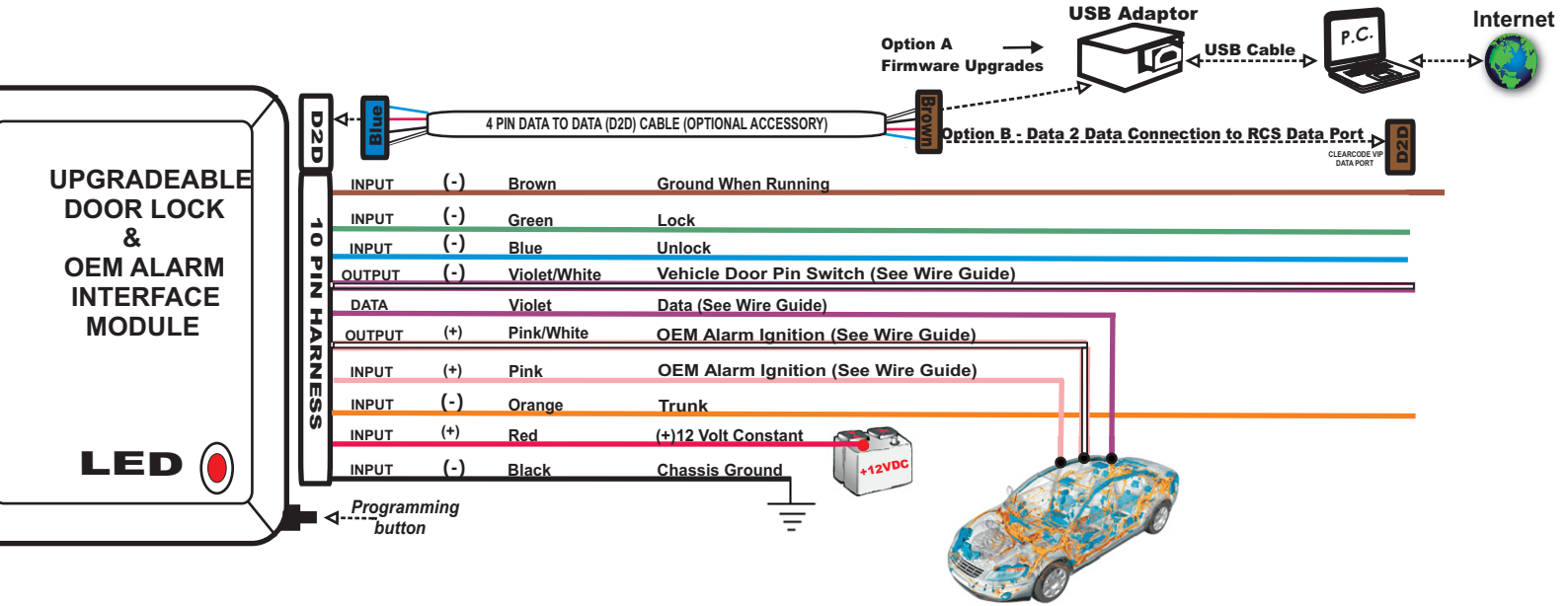

## Section B

### WIRE GUIDE: CONNECTIONS

**10 PIN HARNESS** → D2D = Optional use of 4 Pin Data to Data (D2D) cable will replace the analogue wire (w2w) connection

PIN#	WIRE COLOR	VEHICLE TYPE	D2D w2w	I/O STATUS	(-) / (+)	Connect Location	SPECIFIC WIRE CONNECTION LOCATION	ACTIVATION and/or FUNCTIONALITY
1	Brown	N/A	D2D w2w	Input	(-)	RCS	Ground When Running output of remote starter	OEM Security Arm/Disarm
2	Green	N/A	D2D w2w	Input	(-)	RCS	Connect to (-) Lock Output wire of RCS	Lock All Doors
3	Blue	N/A	D2D w2w	Input	(-)	RCS	Connect to (-) Unlock Output wire of RCS	Unlocks All Doors
4	Violet/White	See Vehicle Type Diagram	w2w	Output	(-)	Vehicle	Connect to Green/Orange wire, fuse box side (See Vehicle Type Diagram for Connections)	Supplies (-) output to vehicle door pin switch in order to arm OEM alarm
5	Violet	See Vehicle Type Diagram	w2w	Data		Vehicle	(See Vehicle Type Diagram for Connections)	Lock/Unlock/Arm/Disarm Via Vehicle Data Wire
6	Pink/White	See Vehicle Type Diagram	w2w	Output	(+)	Vehicle	OEM Alarm Ignition Input (See Vehicle Type Diagram for Connections)	Ignition Power to Alarm Module
7	Pink	See Vehicle Type Diagram	w2w	Input	(+)	Vehicle	OEM Alarm Ignition Output (See Vehicle Type Diagram for Connections)	Ignition from Vehicle Harness
8	Orange	Acura 1.7 ONLY	D2D w2w	Input	(-)	RCS	Connect to (-) Trunk Release Output wire of RCS	Trunk Release *Acura 1.7 ONLY
9	Red	N/A	D2D w2w	Input	(+)	Vehicle	Constant (+) 12 Volt Source	Power Source
10	Black	N/A	D2D w2w	Input	(-)	Vehicle	Chassis Ground	Ground Source

**Legend** RCS = Remote Control System N/C = No Connection N/A = Not Applicable W2W= analogue wire to wire D2D= data 2 data

**DATA to DATA PORT (D2D):** Blue connector of D2D Cable plugs into the upgradeable vehicle interface module.

OPTION A: - D2D Port used to connect to USB Bootloader adaptor & computer to download & flash vehicle interface firmware.

OPTION B: - D2D Port used to connect to the data port of a remote control system equipped with ClearCode Vehicle Interface Protocol.

Remote control systems designed with ClearCode VIP can securely communicate via the D2D cable to transmit & receive data commands which initiate specific vehicle function such as doorlocks & immobilizer override and /or request information from the vehicle such as status of entry points (doors) or ambient temperature, diesel glow plug etc... ClearCode VIP represents the doorway to vehicle integration...

**Description:** Honda/Acura Doorlock Alarm Interface (NO KEY REQUIRED)

**Functions:** Lock/Unlock, Trunk, OEM Security Arm/Disarm

Section C

## VEHICLE TYPE DIAGRAM

### TYPE 1

Civic, CRV, Element, Acura 1.7 EL and Acura EL 2005 type diagram.

Data wire is Blue/Orange located in connector "K" behind fuse box.

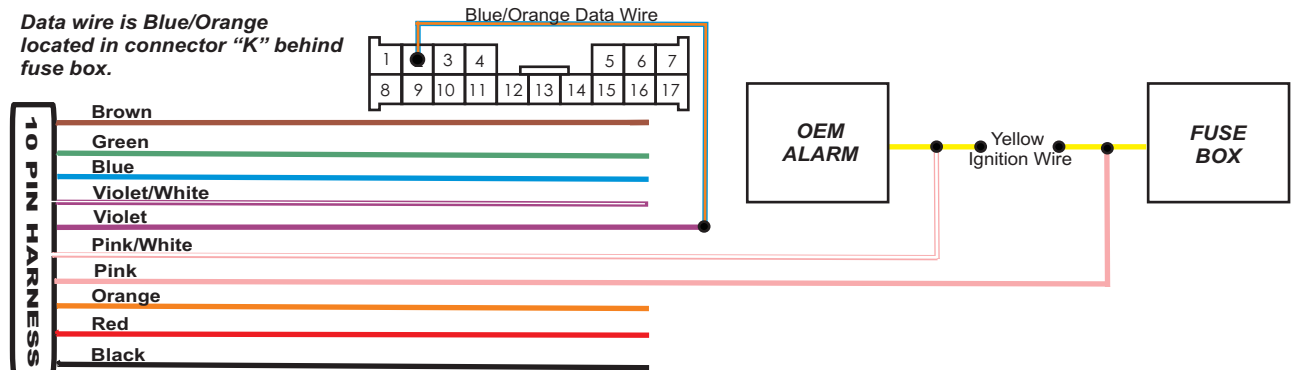

### TYPE 2

Odyssey, Acura TL, Pilot and Accord type diagram.

Data wire (thin Brown wire) on a female connector located from driver door, wire side of fuse box.

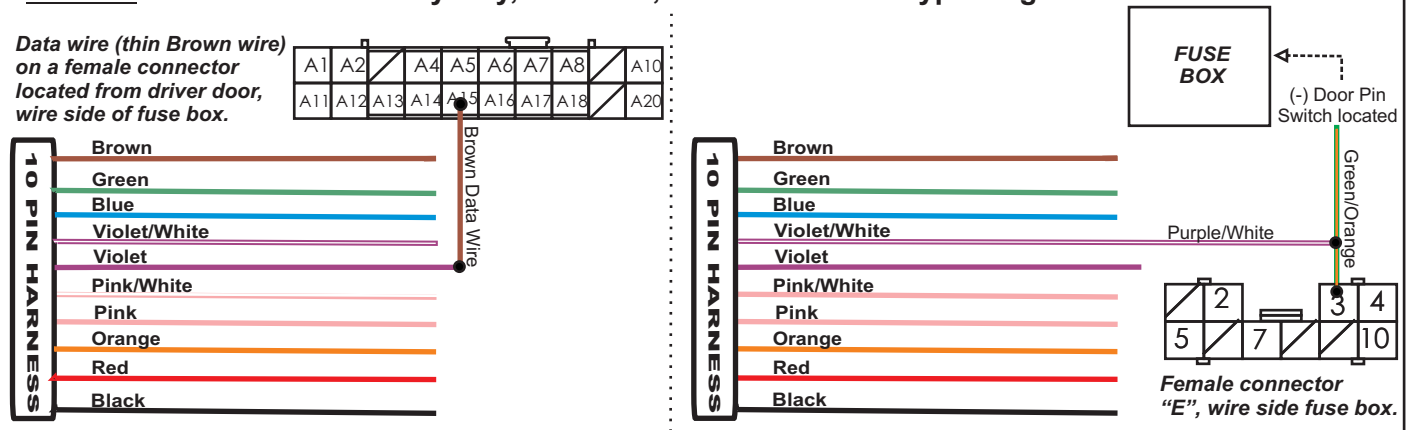

Section D

## VEHICLE TYPE PROGRAMMING

- 1) Connect the module, LED comes ON solid.
- 2) Turn key to ON position. LED turns OFF, then it will begin a flash pattern that matches the vehicle type selection. (The default vehicle type selection is Type 1.)  
*\*If the module has never been programmed or has been reset, LED will indicate which TYPE the module is in by the number of flashes.*
- 3) To change the vehicle type, press and release the program button until LED flash pattern matches the selected vehicle type. LED flash pattern will match the Vehicle Type selected. **Example: 1 flash = Type 1, 2 flashes = Type 2 and so on.**
- 4) To save the vehicle type selection, press and hold the program button until the LED flashes rapidly. The module will then exit the programming. The module is now programmed. *\*If LED comes on solid, turn the key to start the engine.*  
*\*If the module has already been programmed, the number of flashes indicate the type programmed when applying power to module, one time only. Module is now ready to function.*

Section E

## USER SETTINGS - OPTIONAL PROGRAMMING

**NOTE:** When using D2D, Driver's Priority is not available.

**USER MODES** are identified by a slow LED flash pattern. 1 slow flash=Mode1, 2 slow flashes=Mode 2 etc.

- 1) Key "OFF" position, **press** and **hold** program button for 2 seconds, LED will flash rapidly for 2 seconds. Release button, LED will identify the MODE selection with a slow flash pattern (1- 8 slow flashes) and then will identify OPTION selection with a fast flash pattern. (1 or 2 fast flashes)
- 2) To change **MODE**, **push button** one time, LED will confirm **MODE** with slow flash pattern (1-8 slow flashes).
- 3) To change **OPTION SELECTION** within a **MODE**, **press LOCK** or **UNLOCK** button on the aftermarket remote control system. LED will identify option selection with either one or two fast flashes.
- 4) To save and exit programming, **press** and **hold button** until LED flashes one time rapidly, showing end of OPTION programming.

\* = Default

<b>MODE 1 =</b>	<b>*OPTION 1:</b> 1st Pulse Unlock All Doors (Default)	<b>OPTION 2:</b> 1st Pulse Unlock Driver Door, 2nd Pulse Unlock All Doors
<b>MODE 8 =</b>	<b>*OPTION 1:</b> No reset (Default)	<b>OPTION 2:</b> Complete reset of option and module