

Description: Door Lock, Alarm and Features Control Interface (No Key Required)

Functions: Lock/Unlock, Driver's Priority Unlock, Trunk, OEM Security Arm/Disarm, Door Trigger, Hood Trigger.

Downloadable Firmware for Platform# 07: CHDL8, HODL5, PKN3



WARNING: Before beginning your install go to www.INTELLIKITS.com and be sure to print the LATEST corresponding installation manual for the firmware that is flashed to the platform you are using.



CHDL8 WILL ONLY OPERATE IN D2D (DATA TO DATA) MODE. D2D CABLE IS SUPPLIED BY YOUR RCS MANUFACTURER
Before doing your installation, confirm if your RCS (Remote Control System) is D2D compatible.

INSTALLATION FOR CHRYSLER 300/300C 2008 & DODGE GRAND CARAVAN 2008

Section A

See Wire Connection Guide for detailed information regarding wire functionality

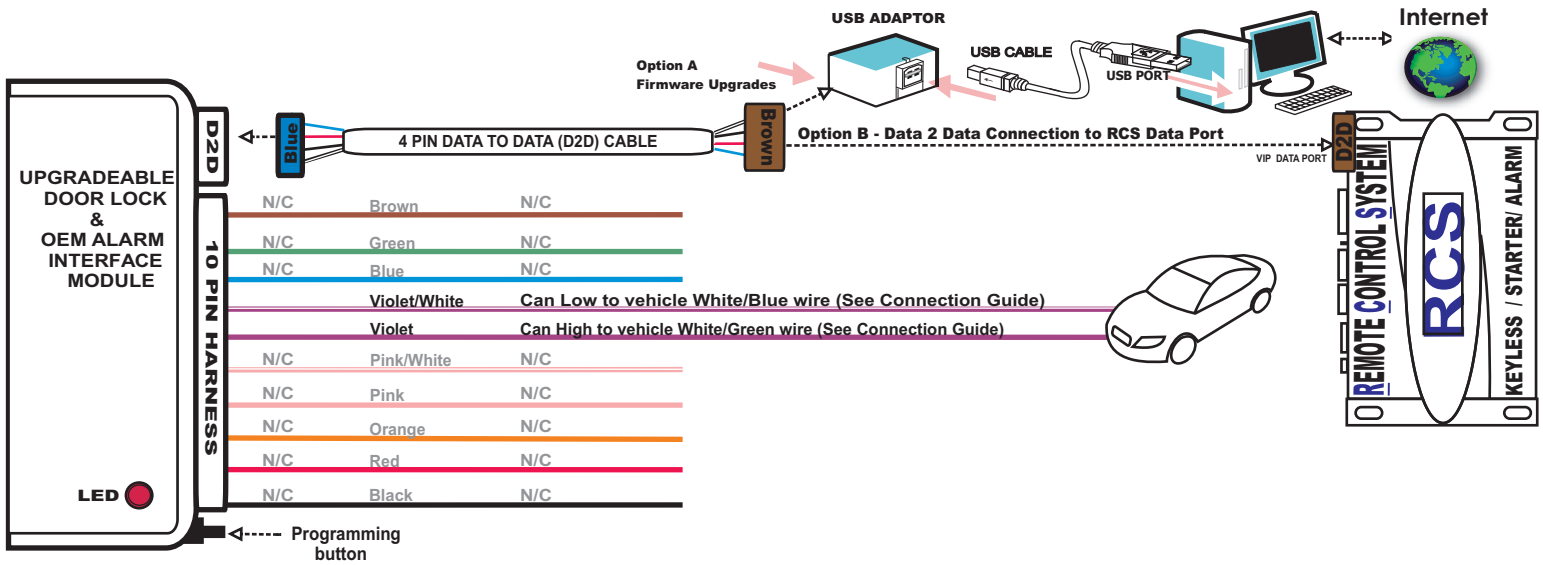

Section B

WIRE GUIDE: CONNECTIONS

10 PIN HARNESS → D2D = Optional use of 4 Pin Data to Data (D2D) cable will replace the analogue wire (w2w) connection

PIN#	WIRE COLOR	D2D w2w	I/O STATUS	(-) /(+)	Connect Location	SPECIFIC WIRE CONNECTION LOCATION	ACTIVATION and/or FUNCTIONALITY
1	Brown	N/C	N/C	N/C	N/C	N/C	N/C
2	Green	N/C	N/C	N/C	N/C	N/C	N/C
3	Blue	N/C	N/C	N/C	N/C	N/C	N/C
4	Violet/White	w2w	Data		Vehicle	Connect to Can Low wire at ignition switch (White/Blue)	Can Low
5	Violet	w2w	Data		Vehicle	Connect to Can High wire at ignition switch (White/Green)	Can High
6	Pink/White	N/C	N/C	N/C	N/C	N/C	N/C
7	Pink	N/C	N/C	N/C	N/C	N/C	N/C
8	Orange	N/C	N/C	N/C	N/C	N/C	N/C
9	Red	N/C	N/C	N/C	N/C	N/C	N/C
10	Black	N/C	N/C	N/C	N/C	N/C	N/C

Legend RCS = Remote Control System N/C = No Connection W2W= analogue wire to wire D2D= data 2 data

DATA to DATA PORT (D2D): Blue connector of D2D Cable plugs into the upgradeable vehicle interface module.
OPTION A: - D2D Port used to connect to USB Bootloader adaptor & computer to download & flash vehicle interface firmware.
OPTION B: - D2D Port used to connect to the data port of a remote control system equipped with ClearCode Vehicle Interface Protocol.
 Remote control systems designed with ClearCode VIP can securely communicate via the D2D cable to transmit & receive data commands which initiate specific vehicle function such as doorlocks & immobilizer override and /or request information from the vehicle such as status of entry points (doors) or ambient temperature, diesel glow plug etc.
 ClearCode VIP represents the doorway to vehicle integration.

Description: Door Lock, Alarm and Features Control Interface (No Key Required)

Functions: Lock/Unlock, Driver's Priority Unlock, Trunk, OEM Security Arm/Disarm, Door Trigger, Hood Trigger.

Section C

VEHICLE PROGRAMMING:

- 1) Once the module has been properly connected, LED comes **ON**.
- 2) Press lock on OEM keyless, LED goes **OFF**. Module is now programmed.

Section D

USER SETTINGS - OPTIONAL PROGRAMMING:

NOTE: When using D2D, Driver's Priority is not available on specific vehicle.

USER MODES are identified by a slow LED flash pattern. 1 slow flash=Mode1, 2 slow flashes=Mode 2 etc.

- 1) Key "OFF" position, **press and hold** program button for 2 seconds, LED will flash rapidly for 2 seconds. Release button, LED will identify the MODE selection with a slow flash pattern (1- 8 slow flashes) and then will identify OPTION selection with a fast flash pattern. (1 or 2 fast flashes)
- 2) To change **MODE**, **push button** one time, LED will confirm **MODE** with slow flash pattern (1-8 slow flashes).
- 3) To change OPTION SELECTION within a MODE, **press LOCK or UNLOCK** button on the aftermarket remote control system. LED will identify option selection with either one or two fast flashes.
- 4) To save and exit programming, **press and hold button** until LED flashes one time rapidly, showing end of OPTION programming.

MODES & OPTIONS LIST

MODE 1: Driver door priority * Option 1: 1st pulse unlock all doors (Default) Option 2: 1st pulse unlock driver door, 2nd pulse unlock all door.	MODE 6: Lock at remote starter stop: *Option 1 = Activate Option 2 = Deactivate	MODE 8: Reset * Option 1: No Reset (Default) Option 2: Complete reset of options and module.
---	--	---

* = Default Value

This Interface kit / Data Bus Interface part has been tested on the listed vehicles. Other vehicles will be added to the select vehicle list upon completion of compatibility testing. Visit website for latest vehicle application guide. **DISCLAIMER:** Under no circumstances shall the manufacturer or the distributors of the bypass kit / data bus interface part(s) be held liable for any consequential damages sustained in connection with the part(s) installation. The manufacturer and it's distributors will not, nor will they authorize any representative or any other individual to assume obligation or liability in relation to the interface kit / data bus interface part(s) other than its replacement. N.B.:Under no circumstances shall the manufacturer and distributors of this product be liable for consequential damages sustained in connection with this product and neither assumes nor authorizes any representative or other person to assume for it any obligation or liability other than the replacement of this product only.