

Platform # 510

Firmware: GMDL6

Installation Manual (1/2 Pages)

Description: Door Lock, Alarm and Trunk Control Interface (KEY REQUIRED)

Functions: Lock/Unlock, Driver's Priority Unlock, Trunk/Rear Glass, OEM Security Arm/Disarm, Data to Analogue, Door Trigger Output (-), Hood Trigger Output (-)

Downloadable Firmware for Platform# 510: AMDL, FODL, GMDL6, HODL4, HYDL, KIADL, KIADL2, TOYDL, VWDL2

WARNING: Before beginning your install go to www.INTELLIKITS.com and be sure to print the LATEST corresponding installation manual for the firmware that is flashed to the platform you are using.

Section A

See Wire Guide for detailed information regarding wire connections & functionality

NOTE: Locate the coil around the ignition.
3 or 5 turns of the loop are required.

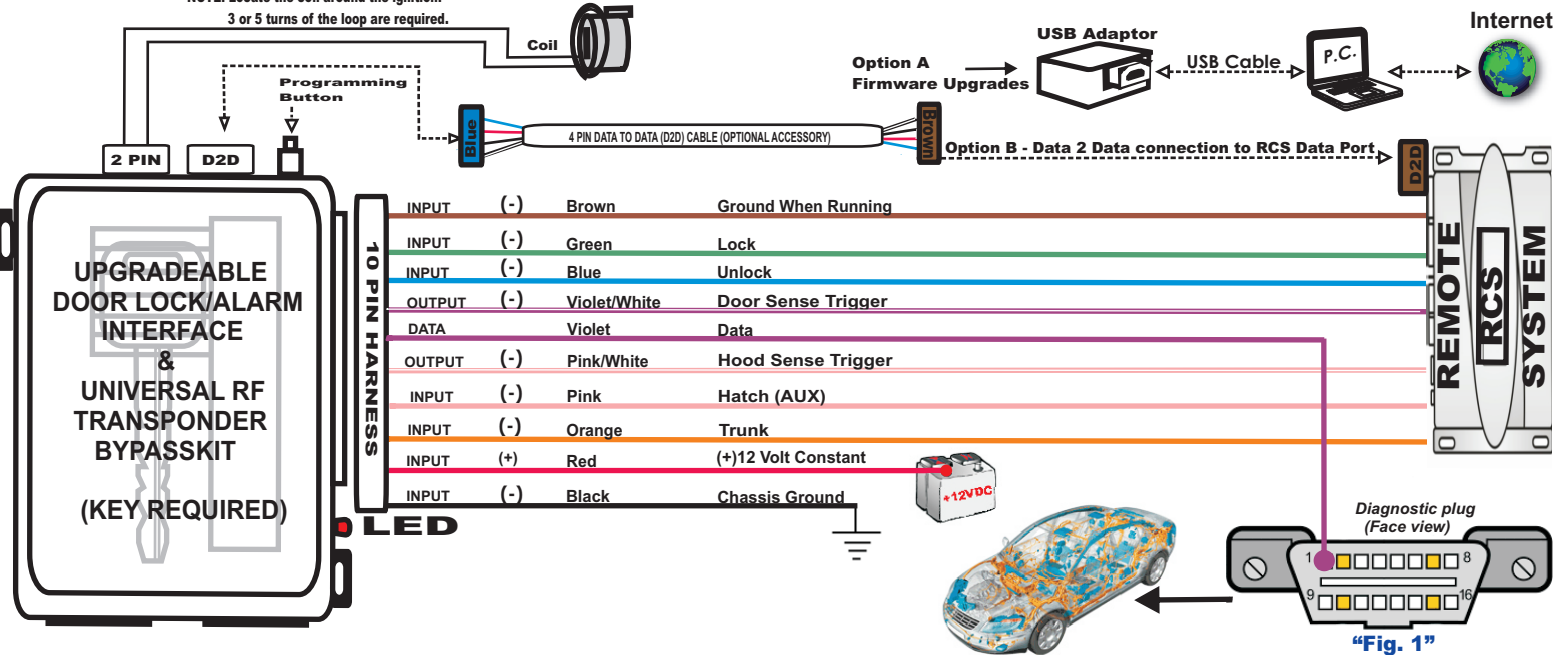

Section B

WIRE GUIDE: CONNECTIONS

10 PIN HARNESS → D2D = Optional use of 4 Pin Data to Data (D2D) cable will replace the analogue wire (w2w) connection

WIRE PIN#	WIRE COLOR	VEHICLE TYPE	D2D w2w	I/O STATUS	(-) / (+)	Connect Location	SPECIFIC WIRE CONNECTION LOCATION	ACTIVATION and/or FUNCTIONALITY
1	Brown	N/A	w2w	Input	(-)	RCS	Ground When Running output of remote starter	RF Transponder Bypass + OEM Security Arm/Disarm
2	Green	N/A	D2D w2w	Input	(-)	RCS	Connect to (-) Lock Output wire of RCS	Lock All Doors
3	Blue	N/A	D2D w2w	Input	(-)	RCS	Connect to (-) Unlock Output wire of RCS	Unlocks All Doors (See User Settings, MODE 1)
4	Violet/White	N/A	D2D w2w	Output	(-)	RCS	Connect to (-) Door Trigger Input wire of RCS	Detects Door status (open/closed) via data bus then converts to an analogue output (-)
5	Violet	N/A	w2w	Data		Vehicle	On Board Diagnostic Connector (OBDII) PIN 1 (Green) Face View Under Dash on Driver Side (See Fig.1)	Data Commands from Module to Vehicle
6	Pink/White	N/A	D2D w2w	Output	(-)	RCS	Connect to (-) Hood Trigger Input wire of RCS	Detects Hood Status Open/Close via Data Bus then converts to an analogue output (-)
7	Pink	N/A	D2D w2w	Input	(-)	RCS	(-) Hatch (AUX)	Open/Close Power Hatch on SUV Type Vehicles
8	Orange	N/A	D2D w2w	Input	(-)	RCS	Trunk Output	Opens Trunk on Cars & Opens Rear Glass on SUV Type Vehicles
9	Red	N/A	D2D	Input	(+)	Vehicle	Constant (+) 12 Volt Source	Power Source
10	Black	N/A	D2D	Input	(-)	Vehicle	Chassis Ground	Ground Source

Legend RCS = Remote Control System N/C = No Connection N/A = Not Applicable W2W= analogue wire to wire D2D= data 2 data

DATA to DATA PORT (D2D) : Blue connector of D2D Cable plugs into the upgradeable vehicle interface module.

OPTION A: - D2D Port used to connect to USB Bootloader adaptor & computer to download & flash vehicle interface firmware.

OPTION B: - D2D Port used to connect to the data port of a remote control system equipped with ClearCode Vehicle Interface Protocol.

Remote control systems designed with ClearCode VIP can securely communicate via the D2D cable to transmit & receive data commands which initiate specific vehicle function such as doorlocks & immobilizer override and /or request information from the vehicle such as status of entry points (doors) or ambient temperature, diesel glow plug etc... ClearCode VIP represents the doorway to vehicle integration...When using D2D cable on a Combo kit which includes RF Transponder Bypass, the Brown GWR wire (10 pin) is a required connection.

Description: Door Lock, Alarm and Trunk Control Interface (No Key Required)

Functions: Lock/Unlock, Driver's Priority Unlock, Trunk/Rear Glass,OEM Security Arm/Disarm, Data to Analogue, Door Trigger Output (-), Hood Trigger Output (-)

Section C

UNIVERSAL TRANSPONDER INSTALLATION:

- 1) Once the wires have been connected properly, open box and insert key inside wire loop, now close box.
- 2) Wrap coil loop around Key Cylinder, 3 to 5 turns of the loop is required. Installation is complete.

Section D

VEHICLE PROGRAMMING:

- 1) Once the module has been properly connected, LED comes **ON**.
- 2) Turn key to **IGNITION** position, LED goes **OFF**. Module is now programmed.

Section E

USER SETTINGS - OPTIONAL PROGRAMMING:

NOTE: When using D2D, Driver's Priority is not available.

USER MODES are identified by a slow LED flash pattern. 1 slow flash=Mode1, 2 slow flashes=Mode 2 etc.

- 1) Key "**OFF**" position, **press** and **hold** program button for 2 seconds, LED will flash rapidly for 2 seconds. Release button, LED will identify the **MODE** selection with a slow flash pattern (1- 8 slow flashes) and then will identify **OPTION** selection with a fast flash pattern. (1 or 2 fast flashes)
- 2) To change **MODE**, **push button** one time, LED will confirm **MODE** with slow flash pattern (1-8 slow flashes).
- 3) To change **OPTION SELECTION** within a **MODE**, **press LOCK or UNLOCK** button on the aftermarket remote control system. LED will identify option selection with either one or two fast flashes.
- 4) To save and exit programming, **press** and **hold button** until LED flashes one time rapidly, showing end of **OPTION** programming.

* = *Default*

MODE 1 =	*OPTION 1: 1st Pulse Unlock All Doors (Default)	OPTION 2: 1st Pulse Unlock Driver Door, 2nd Pulse Unlock All Doors
MODE 8 =	*OPTION 1: No reset (Default)	OPTION 2: Complete reset of option and module