

Platform # 532

Firmware: CHDL6+

Installation Manual (1\2 Pages)

Description: Chrysler Dodge Jeep Combo Door Lock Alarm Interface + 2nd Generation Chrysler Sentry Key RF Transponder Override (NO KEY REQUIRED)

Functions: Data Bus Interface: Lock/Unlock, Trunk/Rear Hatch, Sliding Door RT & LFT, OEM Security Arm/Disarm, Starter Enable, Door Pin Status Output for aftermarket alarm

Downloadable Firmware for Platform #532: CHDL6+, CHDL7

WARNING: Before beginning your install go to www.INTELLIKITS.com and be sure to print the LATEST corresponding installation manual for the firmware that is flashed to the platform you are using.

Section A See Wire Connection Guide for detailed information regarding wire functionality

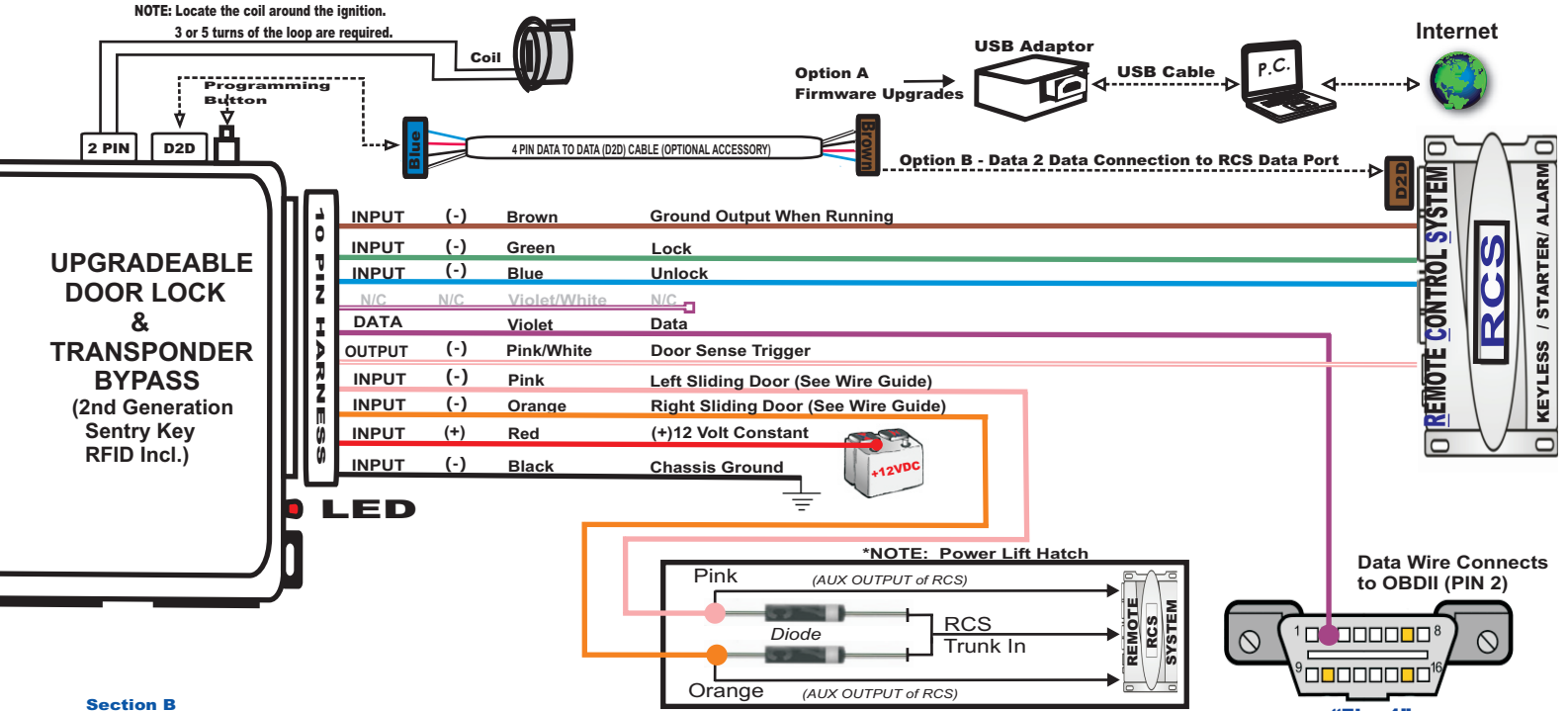

Section B WIRE GUIDE: CONNECTIONS

10 PIN HARNESS → D2D = Optional use of 4 Pin Data to Data (D2D) cable will replace the analogue wire (w2w) connection

| PIN# | WIRE COLOR | VEHICLE TYPE | D2D w2w | I/O STATUS | (-) / (+) | Connect Location | SPECIFIC WIRE CONNECTION LOCATION | ACTIVATION and/or FUNCTIONALITY |
|------|--------------|--------------|---------|------------|-----------|------------------|-----------------------------------------------------------------------------------------------|--------------------------------------------------------------------------------------------------------------------------------------------------------------------------------------|
| 1 | Brown | N/A | w2w | Input | (-) | RCS | Ground When Running output of remote starter | Factory Alarm/Disarm + RF Transponder 2nd Generation Sentry Bypass |
| 2 | Green | N/A | D2D w2w | Input | (-) | RCS | Connect to (-) Lock Output wire of RCS | Lock All Doors |
| 3 | Blue | N/A | D2D w2w | Input | (-) | RCS | Connect to (-) Unlock Output wire of RCS | Unlock All Doors |
| 4 | Violet/White | N/C | N/C | N/C | N/C | N/C | N/C | N/C |
| 5 | Violet | N/A | w2w | Data | | Vehicle | On Board Diagnostic Connector (OBDII) PIN2 Face View Under Dash on Driver Side (See Fig.1) | Data Commands from Module to Vehicle |
| 6 | Pink/White | N/A | D2D w2w | Output | (-) | RCS | Connect to (-) door trigger input wire of RCS | Detects Doors status (open/closed) via data bus then converts to an analogue output (-) |
| 7 | Pink | Type 1 & 2 | D2D w2w | Input | (-) | RCS | AUX Output for Left Sliding Door | 1 sec (-) Pulse Left Slide Door Open/Close |
| 8 | Orange | Type 1 & 2 | D2D w2w | Input | (-) | RCS | AUX Output for Right Sliding Door Trunk or AUX Output | 1 sec (-) Pulse Right Slide Door Open/Close 3 sec (-) Pulse Releases Trunk/Rear Hatch OR 1 sec (-) Pulse simultaneously on Orange & Pink Releases Trunk/Rear Hatch (See Fig.2) |
| 9 | Red | N/A | D2D w2w | Input | (+) | Vehicle | Constant (+) 12 Volt Source | Power Source |
| 10 | Black | N/A | D2D w2w | Input | (-) | Vehicle | Chassis Ground | Ground Source |

Legend RCS = Remote Control System N/C = No Connection N/A = Not Applicable w2w = Wire to Wire D2D = Data to Data

DATA to DATA PORT (D2D): Blue connector of D2D Cable plugs into the upgradeable vehicle interface module.
 OPTION A: - D2D Port used to connect to USB Bootloader adaptor & computer to download & flash vehicle interface firmware.
 OPTION B: - D2D Port used to connect to the data port of a remote control system equipped with ClearCode Vehicle Interface Protocol.
 Remote control systems designed with ClearCode VIP can securely communicate via the D2D cable to transmit & receive data commands which initiate specific vehicle function such as doorlocks & immobilizer override and /or request information from the vehicle such as status of entry points (doors) or ambient temperature, diesel glow plug etc... ClearCode VIP represents the doorway to vehicle integration...When using D2D cable as a Combo kit which includes RF Transponder Bypass, the Brown GWR wire (10 pin) is a required connection.

This Interface kit / Data Bus Interface part has been tested on the listed vehicles. Other vehicles will be added to the select vehicle list upon completion of compatibility testing. Visit website for latest vehicle application guide. **DISCLAIMER:** Under no circumstances shall the manufacturer or the distributors of the bypass kit / data bus interface part(s) be held liable for any consequential damages sustained in connection with the part(s) installation. The manufacturer and its distributors will not, nor will they authorize any representative or any other individual to assume obligation or liability in relation to the interface kit / data bus interface part(s) other than its replacement. N.B.: Under no circumstances shall the manufacturer and distributors of this product be liable for consequential damages sustained in connection with this product neither assumes nor authorizes any representative or other person to assume for it any obligation or liability other than the replacement of this product only.

Description: Chrysler Dodge Jeep Combo Door Lock Alarm Interface + 2nd Generation Chrysler Sentry Key RF Transponder
Override (NO KEY REQUIRED)

Functions: Data Bus Interface: Lock/Unlock, Trunk/Rear Hatch, Sliding Door RT & LFT, OEM Security Arm/Disarm,
Starter Enable, Door Pin Status Output for aftermarket alarm

Section C

STEP #1 TRANSPONDER PROGRAMMING MODE

You will need 2 valid ignition keys. Proceed as follows:

- 1) Insert first valid key into ignition and turn the ignition switch **ON** for at least 5 seconds, but no longer than 15 seconds.
- 2) Turn ignition switch **OFF** and remove first key.
- 3) Within 5 seconds insert the second valid key and turn ignition switch **ON**. After 10 seconds a chime will sound and the security light will begin to flash.
Turn ignition switch **OFF** and remove second key.

YOU NOW HAVE SECONDS TO PROCEED WITH NEXT STEP

- 4) For the next 2 steps, position and hold module (transponder side) close and towards the front of the ignition barrel (key cylinder).
(Coil Loop is **not used** during programming)
- 5) With the help of a jumper wire, power up vehicle ignition.
- 6) After 10 seconds, a chime will sound. The security light will stop flashing, then turn ON for 3 seconds, then turn OFF.
PK (transponder) portion of module is now programmed.

IMPORTANT NOTE:

Once the transponder portion has been programmed to a vehicle, it can not be used on any other vehicle.

STEP #2 DOOR LOCK PROGRAMMING

Once all wire connections have been properly connected:

- 1) Connect module to the 10-pin harness, LED will go **ON** to confirm correct connection.
- 2) Insert key into ignition cylinder, LED will go **OFF**.
- 3) The DATA BUS DOORLOCK INTERFACE MODULE is now programmed.

Section D

VEHICLE TYPE PROGRAMMING:

- 1) Connect the module, LED comes ON solid.
- 2) Turn the ignition key to the **ON** position. LED will turn off then it will begin a flash pattern that matches the vehicle type selection.
(The default vehicle type selection is Type 1.)
***If the module has never been programmed or has been reset, LED will indicate which TYPE the module is in by the number of flashes.**
- 3) To change the vehicle type, press and release the program button until LED flash pattern matches the selected vehicle type.
LED flash pattern will match the Vehicle Type selected. **Example: 1 flash = Type 1, 2 flashes = Type 2 and so on.**
- 4) To save the vehicle type selection, press and hold the program button until the LED flashes rapidly. The module will then exit the programming. The module is now programmed. ***If LED comes on solid, turn the key to start the engine.**
***If the module has already been programmed, the number of flashes indicate the type programmed when applying power to module, one time only. Module is now ready to function.**

Section E

VEHICLE TYPE CHART

Doors, Alarm and Transponder

| VEHICLES | 2006 | 2005 | 2004 |
|----------------|------|------|------|
| GRAND CARAVAN | 2 | 2 | 2 |
| CARAVAN | 2 | 2 | 2 |
| TOWN & COUNTRY | 2 | 2 | 2 |
| PACIFICA | 2 | 2 | 2 |
| LIBERTY | 2 | 2 | N/A |

NOTE: Once you have determined your vehicle type, please refer to the Wire Guide.

Section F

USER SETTINGS - OPTIONAL PROGRAMMING:

NOTE: Only MODES 7 & 8 are available.

USER MODES are identified by a slow LED flash pattern. 1 slow flash=Mode 1, 2 slow flashes=Mode 2 etc.

- 1) Key "OFF" position, **press** and **hold** program button for 2 seconds, LED will flash rapidly for 2 seconds. Release button, LED will identify the MODE selection with a slow flash pattern (1- 8 slow flashes) and then will identify OPTION selection with a fast flash pattern. (1 or 2 fast flashes)
- 2) To change **MODE**, **push button** one time, LED will confirm **MODE** with slow flash pattern (1-8 slow flashes).
- 3) To change OPTION SELECTION within a MODE, **press LOCK or UNLOCK** button on the aftermarket remote control system. LED will identify option selection with either one or two fast flashes.
- 4) To save and exit programming, **press** and **hold button** until LED flashes one time rapidly, showing end of OPTION programming.

* = Default

| | | |
|-----------------|-------------------------------------------------------|------------------------------------------------------|
| MODE 7 = | *OPTION 1: Vehicle with alarm (Default) | OPTION 2: Vehicle without alarm |
| MODE 8 = | *OPTION 1: No reset (Default) | OPTION 2: Complete reset of option and module |